

# VIO-110/PC311E

10.4" SVGA Resistive / Capacitive Touch Panel PC with Intel® Core™ i5/i3 or Celeron® Processor, 1x PCIe x4 Expansion

## FEATURES

- 10.4" TFT SVGA 4:3 LCD with resistive 5-wire / projected capacitive Touch
- Intel® Core™ processor i5-5350U, up to 2.9GHz / i3-5010U, 2.1GHz or Celeron® 3765U, 1.9GHz
- 1x 204-pin DDR3L SODIMM. max up to 8GB
- 1x 2.5" SATA HDD bay support RAID 0,1, 5, 2x mSATA, 2x SIM socket
- 2x full-size mini PCIe for communication or expansion modules
- 1x PCIe x4 expansion
- 2x LAN, 1x VGA, 1x DisplayPort
- 4x RS-232/422/485 (w/ 2x internal), 3x USB 3.0, 1x USB 2.0, Audio, DIO
- 9 to 48VDC wide range power input
- -10°C to 60°C extended operating temperature
- Designed with aluminum die-casting front frame
- IP65 compliant front panel
- Two 5W internal speakers built-in
- Multi-language OSD built-in



## SPECIFICATIONS

### DISPLAY

LCD Size	10.4" (4:3)
Max. Resolution	800 x 600 (SVGA)
Brightness (cd/m <sup>2</sup> )	400
Contrast Ratio	700:1
LCD Color	16.2M
Pixel Pitch (mm)	0.264 (H) x 0.264 (V)
Viewing Angle (H-V)	160 / 130
Backlight MTBF	50000 hrs (LED Backlight)

### TOUCH

Resistive 5-wire	VIO-110R/PC311E Only
Projected Capacitive	VIO-110C/PC311E Only

### SYSTEM

Processor	- 5 <sup>th</sup> Gen Intel® Core™ i5-5350U Processor, Dual Core, 3MB Cache, up to 2.9 GHz - 5 <sup>th</sup> Gen Intel® Core™ i3-5010U Processor, Dual Core, 3MB Cache, 2.1 GHz - 5 <sup>th</sup> Gen Intel® Celeron® Processor 3765U, Dual Core, 2MB Cache, 1.9 GHz
System Chipset	SoC integrated
LAN Chipset	GbE1: Intel® I210-AT (Support Wake-on-LAN and PXE) GbE2: Intel® I218-LM (Support Wake-on-LAN and PXE)
Audio Codec	Realtek ALC888S
System Memory	1x 204-Pin DDR3L 1333/1600MHz SODIMM. Max. up to 8GB
BIOS	AMI 128Mbit SPI BIOS
Watchdog	Software Programmable Supports 1~255 sec. System Reset

### STORAGE

SSD/HDD	1x Removable 2.5" SATA HDD Bay Support RAID 0, 1, 5
mSATA	2x mSATA (Shared by 2x Mini PCIe)
SIM Socket	2x External SIM socket

### EXPANSION

Mini PCI Express	2x Full-size Mini PCIe
PCI Express	1x PCIe x4

### OTHER FEATURES

Internal Speaker	AMP 5W + 5W
OSD	LCD On/Off, Auto, Menu, Up and Down Multi-language

### I/O

VGA	1x VGA (or 1x DVI-D by Order)
DisplayPort	1x DisplayPort
COM	2x RS-232/422/485 2x RS-232/422/485 (internal)
USB	3x USB 3.0, 1x USB 2.0
LAN	2x RJ45
Audio	1x Mic-in, 1x Speaker-out
DIO	4 in / 4 out (Isolated)
Universal I/O Bracket	1x Universal I/O Bracket (By mini PCIe interface)
Others	3x WiFi Antenna Holes 1x Power Switch, 1x AT/ATX Switch, 1x Remote Power On/Off

### OPERATING SYSTEM

Windows	Windows 10, Windows 8.1, WES8.1, Windows 7, WES7
Linux	Linux kernel 3.X

### POWER

Power Mode	AT, ATX
Power Supply Voltage	9~48VDC
Power Ignition Sensing	Power Ignition Management
Power Connector	3-pin Terminal Block
Power Adaptor	Optional AC/DC 12V/5A, 60W
Power Protection	OVP (Over Voltage Protection) OCP (Over Current Protection) Reverse Protection

### ENVIRONMENT

Operating Temp.	-10°C to 60°C
Storage Temp.	-20°C to 70°C
Relative Humidity	10%~80% (non-condensing)
IP Level	IP 65 Compliant Front Panel
Standards / Certification	CE, FCC Class A

### PHYSICAL

Front Panel Construction	Die-cast Flat Surface
Dimension	300 (W) x 238.5 (D) x 86.7 (H)mm
Weight	VIO-110R/PC311E: 4.64 kg VIO-110C/PC311E: 4.57 kg
Mounting	VESA Mounting Holes 75 x 75mm, 100 x 100mm

## EXTERNAL I/O MECHANICAL LAYOUT

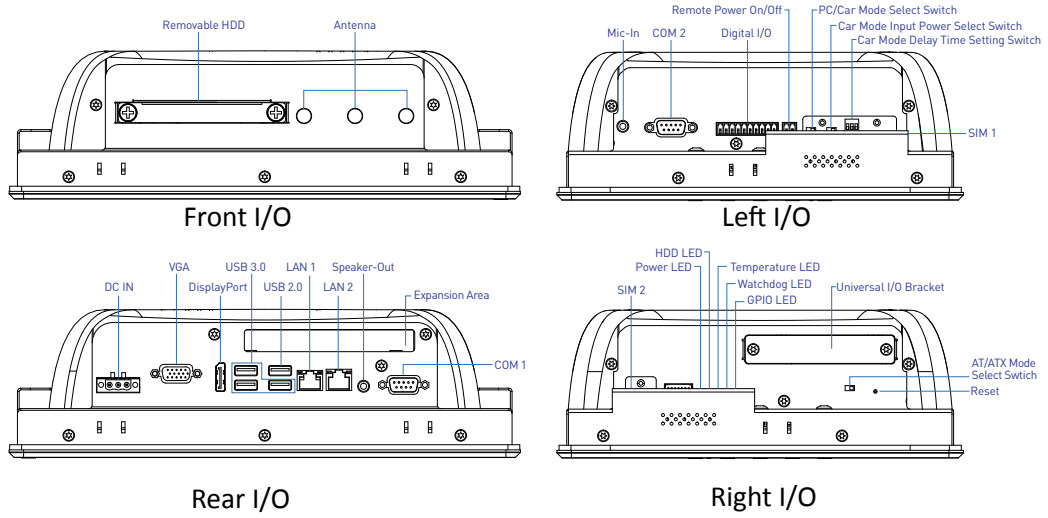

## DIMENSION

Unit: mm

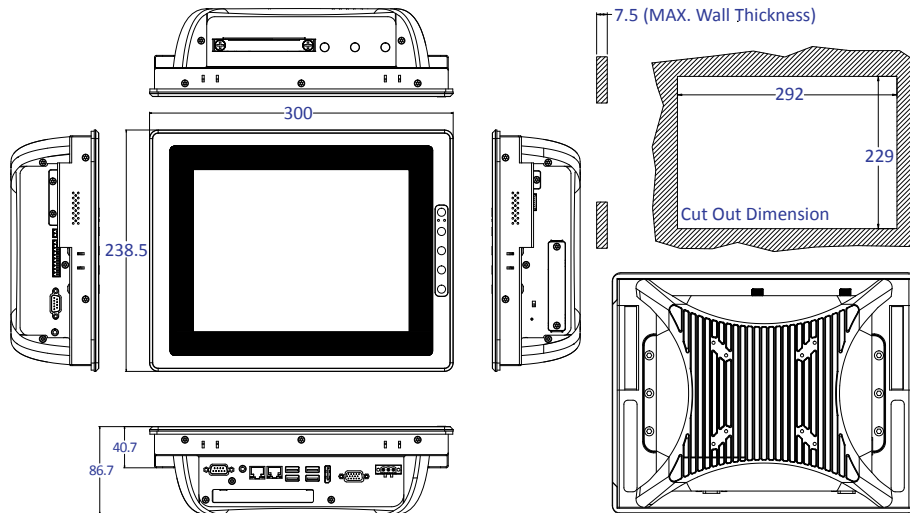

### AVAILABLE MODELS

MODEL NO.	DESCRIPTION
VIO-110R/PC311E-5350U	10.4" SVGA Resistive Touch Panel PC with Intel® i5-5350U Processor, 1x PCIe x4 Expansion
VIO-110C/PC311E-5350U	10.4" SVGA Capacitive Touch Panel PC with Intel® i5-5350U Processor, 1x PCIe x4 Expansion
VIO-110R/PC311E-5010U	10.4" SVGA Resistive Touch Panel PC with Intel® i3-5010U Processor, 1x PCIe x4 Expansion
VIO-110C/PC311E-5010U	10.4" SVGA Capacitive Touch Panel PC with Intel® i3-5010U Processor, 1x PCIe x4 Expansion
VIO-110R/PC311E-3765U	10.4" SVGA Resistive Touch Panel PC with Intel® Celeron® 3765U Processor, 1x PCIe x4 Expansion
VIO-110C/PC311E-3765U	10.4" SVGA Capacitive Touch Panel PC with Intel® Celeron® 3765U Processor, 1x PCIe x4 Expansion

### OPTIONAL ACCESSORIES

MODEL NO.	DESCRIPTION
1-E09A06007	Adapter AC/DC 12V 5A 60W with 3pin Terminal Block Plug 5.0mm Pitch
SFICBL022	Power Cord, 3-pin US Type, 180cm
1-TPCD00002	Power Cord, European Type, 180cm
1-TPCD00001	Power Cord, 3-pin UK Type, 180cm

### PACKING LIST

- 1x VIO-110/PC300 Series Panel PC
- 6x Panel Mount Kit
- 1x Utility DVD Driver
- 1x Screw Pack