

VIO-115

15" XGA Resistive / Capacitive Touch Display Module with 2x 10W Speaker

FEATURES

- 15" TFT XGA 4:3 LCD with Resistive 5-wire /Capacitive Touch
- -10°C to 60°C extended operating temperature
- Designed with Aluminum Die-Casting Front Frame
- IP65 Compliant Front Panel
- Two 10W Internal Speakers Built-in
- Multi-language OSD built-in

SPECIFICATIONS

DISPLAY

LCD Size	15" (4:3)
Max. Resolution	1024 x 768 (XGA)
Brightness (cd/m ²)	350
Contrast Ratio	700:1
LCD Color	16.2M
Pixel Pitch (mm)	0.297 (H) x 0.297 (V)
Viewing Angle (H-V)	170 / 160
Backlight MTBF	50000 hrs (LED Backlight)

TOUCH

Resistive 5-wire	VIO-115R Only
Projected Capacitive	VIO-115C Only



I/O

Internal Speaker	AMP 10W + 10W
OSD	LCD On/Off, Auto, Menu, Up and Down Multi-language

ENVIRONMENT

Operating Temp.	-10°C to 60°C
Storage Temp.	-20°C to 65°C
Relative Humidity	10%~80% (non-condensing)
IP Level	IP 65 Compliant Front Panel

PHYSICAL

Front Panel Construction	Die-cast Flat Surface
Dimension	397 (W) x 306 (D) x 35.7 (H)mm
Weight	VIO-115R: 4.23kg VIO-115C: 4.20kg
Mounting	VESA Mounting Holes 75 x 75mm, 100 x 100mm

DIMENSION

Unit: mm

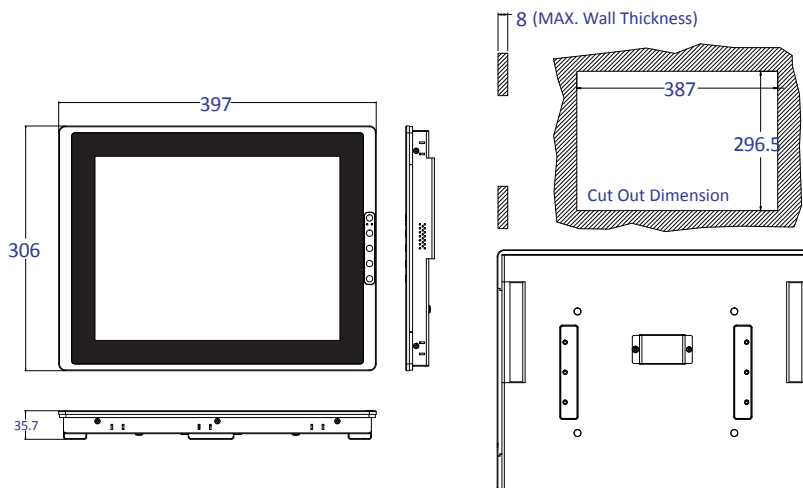

AVAILABLE MODELS

MODEL NO.	DESCRIPTION
VIO-115R	15" XGA Resistive Touch Display Module with 2x 10W Speaker
VIO-115C	15" XGA Capacitive Touch Display Module with 2x 10W Speaker

PACKING LIST

- 1x VIO-115 Series Display Module
- 10x Panel Mount Kit