

# VIO-212/MX100

12.1" XGA Resistive / Capacitive Touch Monitor  
with 2x 5W Speaker

## FEATURES

- 12.1" TFT XGA 4:3 LCD with Resistive 5-wire / Projected Capacitive Touch
- 1x VGA, 1x DVI-D, 1x DisplayPort, 1x USB 2.0, 1x COM, 1x Audio
- 9 to 48VDC wide range power input
- -10°C to 60°C extended operating temperature
- Designed with Aluminum Die-Casting Front Frame
- IP65 Compliant Front Panel
- Two 5W Internal Speakers Built-in
- Multi-language OSD built-in



## SPECIFICATIONS

### DISPLAY

LCD Size	12.1" (4:3)
Max. Resolution	1024 x 768 (XGA)
Brightness (cd/m2)	500
Contrast Ratio	700:1
LCD Color	16.2M
Pixel Pitch (mm)	0.24 (H) x 0.24 (V)
Viewing Angle (H-V)	160 / 160
Backlight MTBF	50000 hrs (LED Backlight)

### TOUCH

Resistive 5-wire	VIO-212R/MX100 only
Projected Capacitive	VIO-212C/MX100 only

### I/O

VGA Input	1x VGA Input
DVI-D Input	1x DVI-D Input
DisplayPort Input	1x DisplayPort Input
USB 2.0 Input	1x USB 2.0 Input
COM Port Input	1x COM Port Input
Audio Input	1x Audio Input

### OTHER FEATURES

Internal Speaker	AMP 5W + 5W
OSD	LCD On/Off, Auto, Menu, Up and Down, Multi-language

### POWER

Power Supply Voltage	9~48VDC
Power Ignition Sensing	Power Ignition Management
Power Connector	3-pin Terminal Block
Power Adaptor	Optional AC/DC 12V/5A, 60W
Power Protection	OVP (Over Voltage Protection) OCP (Over Current Protection) Reverse Protection

### ENVIRONMENT

Operating Temp.	-10°C to 60°C
Storage Temp.	-20°C to 70°C
Relative Humidity	10%~80% (non-condensing)
IP Level	IP 65 Compliant Front Panel
Standards / Certification	CE, FCC Class A

### PHYSICAL

Front Panel Construction	Die-cast Flat Surface
Dimension	319 (W) x 257 (D) x 61.7 (H) mm
Weight	VIO-212R/MX100: 4.20 kg VIO-212C/MX100: 4.14 kg
Mounting	VESA Mounting Holes 75 x 75mm, 100 x 100mm

Rear I/O

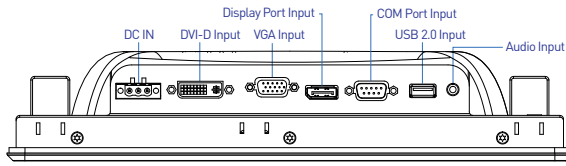

Right I/O

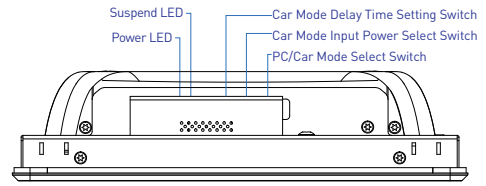

DIMENSION

Unit: mm

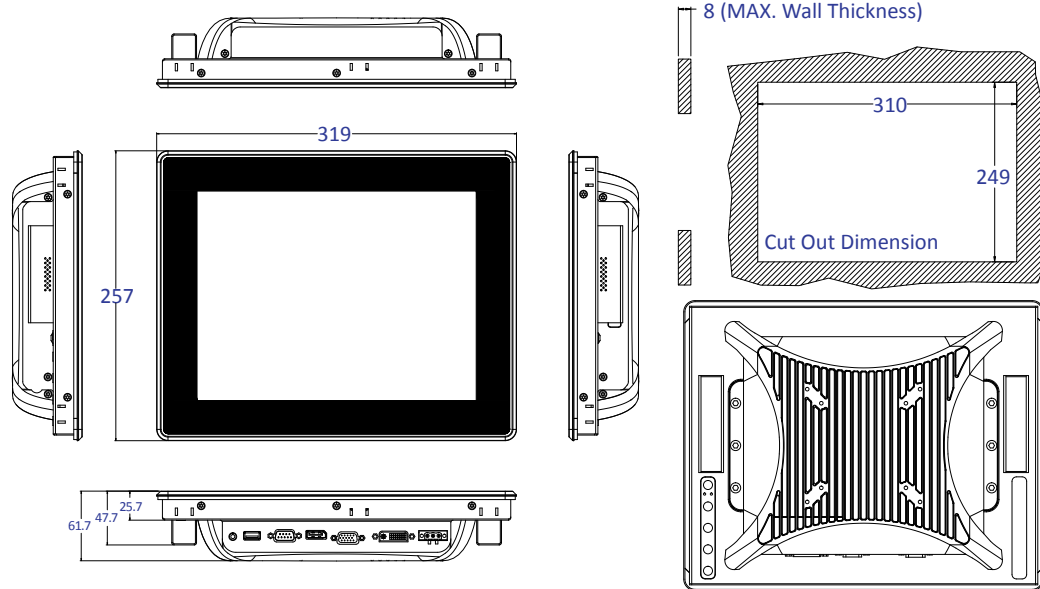

AVAILABLE MODELS

MODEL NO.	DESCRIPTION
VIO-212R/MX100	12.1" XGA Resistive Touch Thin Frame Monitor with 2x 5W Speaker
VIO-212C/MX100	12.1" XGA Capacitive Touch Thin Frame dMonitor with 2x 5W Speaker

OPTIONAL ACCESSORIES

MODEL NO.	DESCRIPTION
1-E09A06007	Adapter AC/DC 12V 5A 60W with 3pin Terminal Block Plug 5.0mm Pitch
SFICBL022	Power Cord, 3-pin US Type, 180cm
1-TPCD00002	Power Cord, European Type, 180cm
1-TPCD00001	Power Cord, 3-pin UK Type, 180cm

PACKING LIST

- 1x VIO-212/MX100 Series Touch Monitor
- 10x Panel Mount Kit
- 1x USB Cable
- 1x VGA Cable
- 1x Screw Pack