

# VIO-219/PC300

19" SXGA Resistive / Capacitive Touch Thin Frame Panel PC with Intel® Core™ i5/i3 or Celeron® Processor

## FEATURES

- 19" TFT SXGA 4:3 LCD with resistive 5-wire / projected capacitive touch
- Intel® Core™ processor i5-5350U, up to 2.9GHz / i3-5010U, 2.1GHz or Celeron® 3765U, 1.9GHz
- 1x 204-pin DDR3L SODIMM. max up to 8GB
- 1x 2.5" SATA HDD bay support RAID 0,1, 5, 2x mSATA, 2x SIM socket
- 2x Full-size mini PCIe for communication or expansion modules
- 2x LAN, 1x VGA, 1x DisplayPort
- 4x RS-232/422/485 (w/ 2x internal), 3x USB 3.0, 1x USB 2.0, Audio, DIO
- 9 to 48VDC wide range power input
- -10°C to 50°C extended operating temperature
- Designed with aluminum die-casting front Frame
- IP65 compliant front panel
- Two 10W internal speakers built-in
- Multi-language OSD built-in

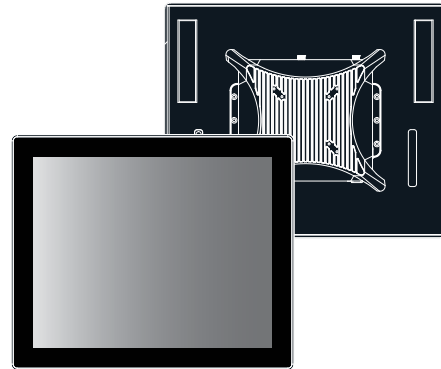

## SPECIFICATIONS

| DISPLAY                         |  |
|---------------------------------|--|
| LCD Size                        | 19" (4:3)  |
| Max. Resolution                 | 1280 x 1024 (SXGA)   |
| Brightness (cd/m <sup>2</sup> ) | 350  |
| Contrast Ratio                  | 1000:1   |
| LCD Color                       | 16.7M  |
| Pixel Pitch (mm)                | 0.294 (H) x 0.294 (V)  |
| Viewing Angle (H-V)             | 170 / 160  |
| Backlight MTBF                  | 50000 hrs (LED Backlight)  |
| TOUCH                           |  |
| Resistive 5-wire                | VIO-219R/PC300 Only  |
| Projected Capacitive            | VIO-219C/PC300 Only  |
| SYSTEM                          |  |
| Processor                       | - 5 <sup>th</sup> Gen Intel® Core™ i5-5350U Processor, Dual Core, 3MB Cache, up to 2.9 GHz<br>- 5 <sup>th</sup> Gen Intel® Core™ i3-5010U Processor, Dual Core, 3MB Cache, 2.1 GHz<br>- 5 <sup>th</sup> Gen Intel® Celeron® Processor 3765U, Dual Core, 2MB Cache, 1.9 GHz |
| System Chipset                  | SoC integrated   |
| LAN Chipset                     | GbE1: Intel® I210-AT (Support Wake-on-LAN and PXE)<br>GbE2: Intel® I218-LM (Support Wake-on-LAN and PXE)   |
| Audio Codec                     | Realtek ALC888S  |
| System Memory                   | 1x 204-Pin DDR3L 1333/1600MHz SODIMM. Max. up to 8GB   |
| BIOS                            | AMI 128Mbit SPI BIOS   |
| Watchdog                        | Software Programmable Supports 1~255 sec. System Reset   |
| STORAGE                         |  |
| SSD/HDD                         | 1x Removable 2.5" SATA HDD Bay Support RAID 0, 1, 5  |
| mSATA                           | 2x mSATA (Shared by 2x Mini PCIe)  |
| SIM Socket                      | 2x External SIM socket   |
| EXPANSION                       |  |
| Mini PCI Express                | 2x Full-size Mini PCIe   |
| OTHER FEATURES                  |  |
| Internal Speaker                | AMP 10W + 10W  |
| OSD                             | LCD On/Off, Auto, Menu, Up and Down Multi-language   |

| I/O         |   |
|-------------|---|
| VGA         | 1x VGA (or 1x DVI-D by Order)   |
| DisplayPort | 1x DisplayPort  |
| COM         | 2x RS-232/422/485<br>2x RS-232/422/485 (internal)                                     |
| USB         | 3x USB 3.0, 1x USB 2.0  |
| LAN         | 2x RJ45   |
| Audio       | 1x Mic-in, 1x Speaker-out   |
| DIO         | 4 in / 4 out (Isolated)   |
| Others      | 3x WiFi Antenna Holes<br>1x Power Switch, 1x AT/ATX Switch,<br>1x Remote Power On/Off |

| OPERATING SYSTEM |  |
|------------------|--|
| Windows          | Windows 10, Windows 8.1, WES8.1, Windows 7, WES7 |
| Linux            | Linux kernel 3.X                                 |

| POWER                  |  |
|------------------------|--|
| Power Mode             | AT, ATX  |
| Power Supply Voltage   | 9~48VDC  |
| Power Ignition Sensing | Power Ignition Management  |
| Power Connector        | 3-pin Terminal Block   |
| Power Adaptor          | Optional AC/DC 12V/5A, 60W   |
| Power Protection       | OVP (Over Voltage Protection)<br>OCP (Over Current Protection)<br>Reverse Protection |

| ENVIRONMENT               |                             |
|---------------------------|-----------------------------|
| Operating Temp.           | -10°C to 50°C               |
| Storage Temp.             | -20°C to 60°C               |
| Relative Humidity         | 10%~80% (non-condensing)    |
| IP Level                  | IP 65 Compliant Front Panel |
| Standards / Certification | CE, FCC Class A             |

| PHYSICAL                 |  |
|--------------------------|--|
| Front Panel Construction | Die-cast Flat Surface                              |
| Dimension                | 450 (W) x 375 (D) x 71 (H)mm                       |
| Weight                   | VIO-219R/PC300: 7.88 kg<br>VIO-219C/PC300: 7.75 kg |
| Mounting                 | VESA Mounting Holes<br>75 x 75mm, 100 x 100mm      |

## EXTERNAL I/O MECHANICAL LAYOUT

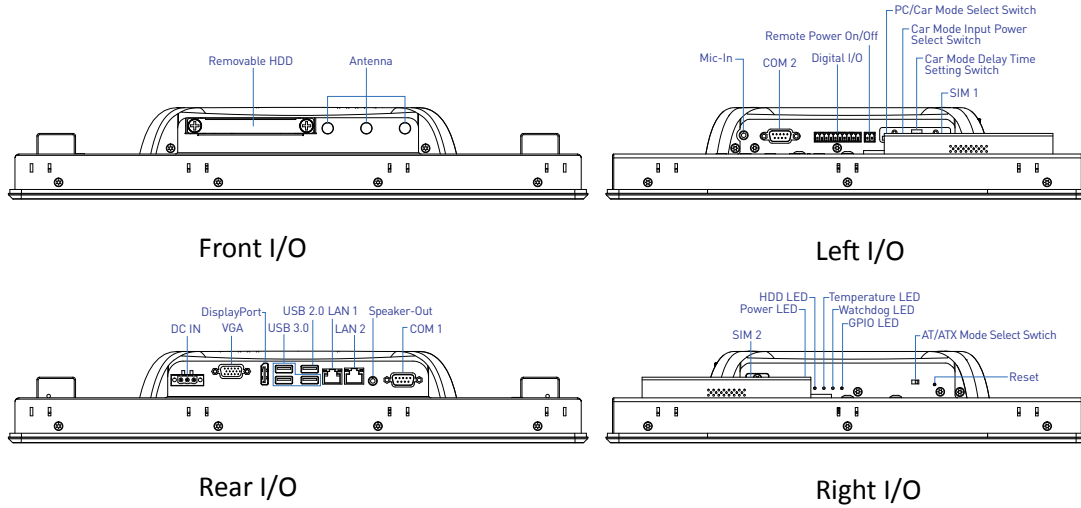

## DIMENSION

Unit: mm

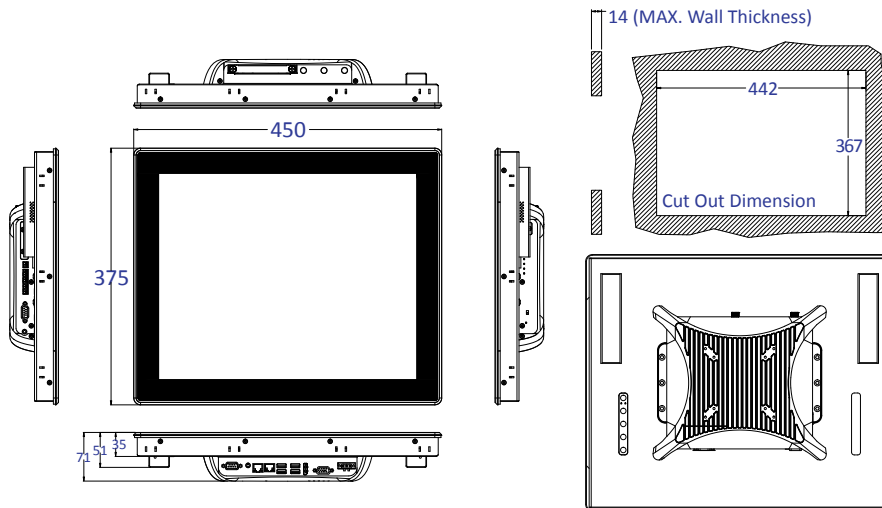

## AVAILABLE MODELS

| MODEL NO.            | DESCRIPTION  |
|----------------------|--|
| VIO-219R/PC300-5350U | 19" SXGA Resistive Touch Thin Frame Panel PC with Intel® i5-5350U Processor        |
| VIO-219C/PC300-5350U | 19" SXGA Capacitive Touch Thin Frame Panel PC with Intel® i5-5350U Processor       |
| VIO-219R/PC300-5010U | 19" SXGA Resistive Touch Thin Frame Panel PC with Intel® i3-5010U Processor        |
| VIO-219C/PC300-5010U | 19" SXGA Capacitive Touch Thin Frame Panel PC with Intel® i3-5010U Processor       |
| VIO-219R/PC300-3765U | 19" SXGA Resistive Touch Thin Frame Panel PC with Intel® Celeron® 3765U Processor  |
| VIO-219C/PC300-3765U | 19" SXGA Capacitive Touch Thin Frame Panel PC with Intel® Celeron® 3765U Processor |

## OPTIONAL ACCESSORIES

| MODEL NO.   | DESCRIPTION  |
|-------------|--|
| 1-E09A06007 | Adapter AC/DC 12V 5A 60W with 3pin Terminal Block Plug 5.0mm Pitch |
| SFICBL022   | Power Cord, 3-pin US Type, 180cm                                   |
| 1-TPCD00002 | Power Cord, European Type, 180cm                                   |
| 1-TPCD00001 | Power Cord, 3-pin UK Type, 180cm                                   |

## PACKING LIST

- 1x VIO-219/PC300 Series Panel PC
- 14x Panel Mount Kit
- 1x Utility DVD Driver
- 1x Screw Pack