

## HPC150GR-FP6200

15.0" TFT Fanless Touch Panel Computer with Intel® Skylake i5-6200U 2.3GHz Dual Cores Processor

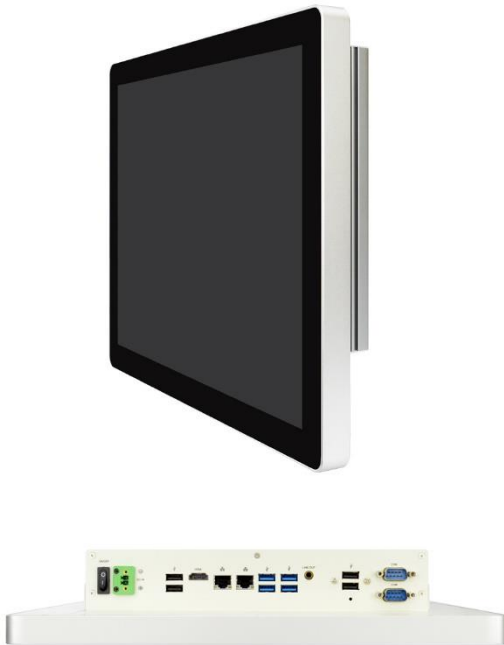

1. 15.0" 450 nits high brightness TFT LCD with LED backlight
2. 5 Wire Resistive Touch/Anti-Reflection Protection Glass
3. Cable less, Streamlined enclosure for highly efficient heat dissipation Enclosed in robust aluminum casings
4. Strong solid aluminum frame design and fanless cooling system
5. Support Open frameless design
6. Design for easy Wall mount, Panel Mount, VESA Mount installation
7. A true Flat, easy-to-clean front surface with edge-to-edge design
8. USB3.0 Support Lock Device
9. Front IP65 for protection against water and dust
10. 9-24V DC-input Support, with EOS, OVP design

### External I/O

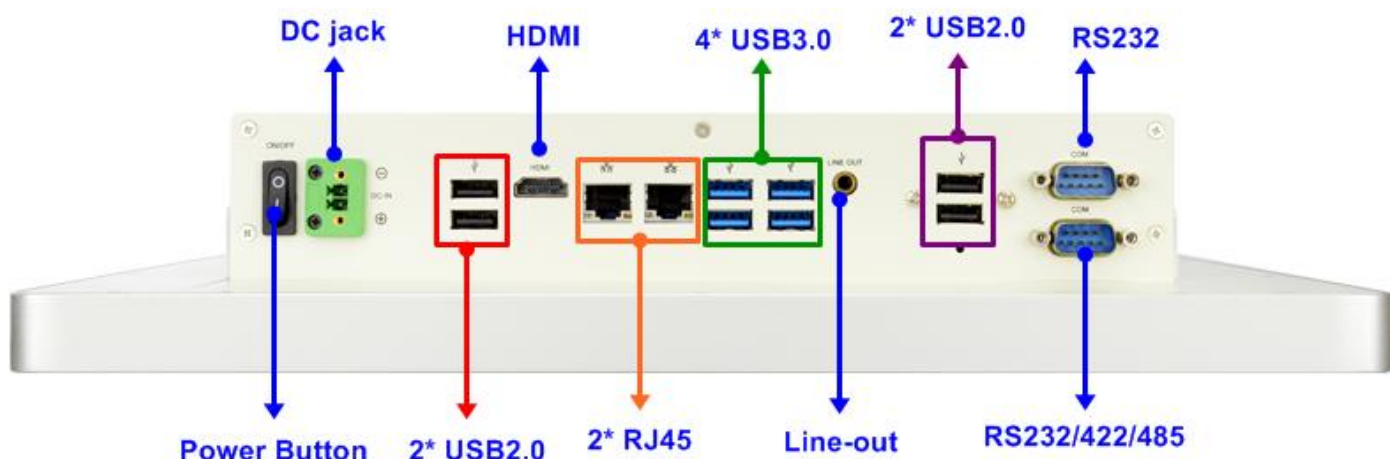

## Specifications

<b>Display</b>	
Front Bezel	- IP65, NEMA 4 rugged protection, metal front bezel
Display Type	- 15.0" With LED Backlight
Brightness (cd/m <sup>2</sup> )	- 450 nits
Display Color	- 262K
Resolution	- 1024 x 768 @ 60Hz
Viewing Angle (H/V)	- 160°/160°
Pixel Pitch	- 0.297 x 0.297 mm
Aspect Ratio	- 4:3
Contrast Ratio	- 800:1
Response Time	- 12ms
<b>Touch screen</b>	
Type	- 5 wires analog resistive type
Active Range	- 306.60 x 230.60mm ±0.2mm
Transparency	- 80 ±3%
Operating Force	- ≤ 50g
Surface Hardness	- ≧ 3H ( pressure 750g/45°)
Knock test	- 10,000,000 times keystrokes
<b>CASE</b>	
Panel Material	- Aluminum
Case Material	- Iron
Color	- Silver + white
Coating Requirement	- Spray Paint
<b>Main System</b>	
CPU	- Intel® Skylake i5-6200U 2.3GHz/DC
RAM	- 2* DDR4 SO-DIMM (Max 32GB)
BIOS	- 128MB SPI Flash ROM
Storage	- 1* 2.5" SATA HDD - 1* mSATA (Full size)
Watchdog Timer	- 256 levels, 0~255 sec.
OS Support	- Windows 7 / 8.1 / 10 / Linux(Optional)
<b>I/O Connector</b>	
I/O Ports and Switches	- 4* USB3.0 + 4* USB2.0 - 1* RS232/422/485 + 1* RS232 - 1* HDMI - 1* Line-out

	<ul style="list-style-type: none"> <li>- 2* LAN (Intel® I211AT + I219LM Gigabit LAN)</li> <li>- 1* Locking Jack 9~24V DC input</li> <li>- 1* Power button</li> </ul>
<b>Expansion Interface</b>	
Expansion	- 1* PCI-E mini card for WIFI or 3G/4G
<b>Power</b>	
Power Input	<ul style="list-style-type: none"> <li>- AC version: 100~240V AC-DC 60W power adapter or</li> <li>- DC version: 12Vdc with over current protection fuse</li> </ul>
Power Consumption	- 40W
<b>Dimensions</b>	
Case Dimensions	- 352.0*279.5*66.5mm
Packing Dimensions	<ul style="list-style-type: none"> <li>- Net Weight: KG</li> <li>- Gross Weight: KG</li> <li>- Color Box dimension: (W) * (D) * (H) mm</li> </ul>
<b>Certifications</b>	
Certifications	- CE, FCC, IP65(Front)
<b>Environment</b>	
Temperature	- Operating: -10°C ~ 50°C (with W.T. DRAM/HDD in airflow condition)
	- Operating: -10°C ~ 50°C (with W.T. DRAM/HDD)
	- Storage: -20°C ~ 70°C
Shock	- Operating: 15G , 11ms duration
Vibration	- Operating: 5~500Hz/1 Grms
<b>Warranty</b>	
Warranty	- 2 Years Limited Warranty (Panel is only 1Year Warranty)

\*Specifications subject to change without notice, not responsible for typographical errors. Does not include HDD or OS.

## Mechanical Drawings (Unit = mm)

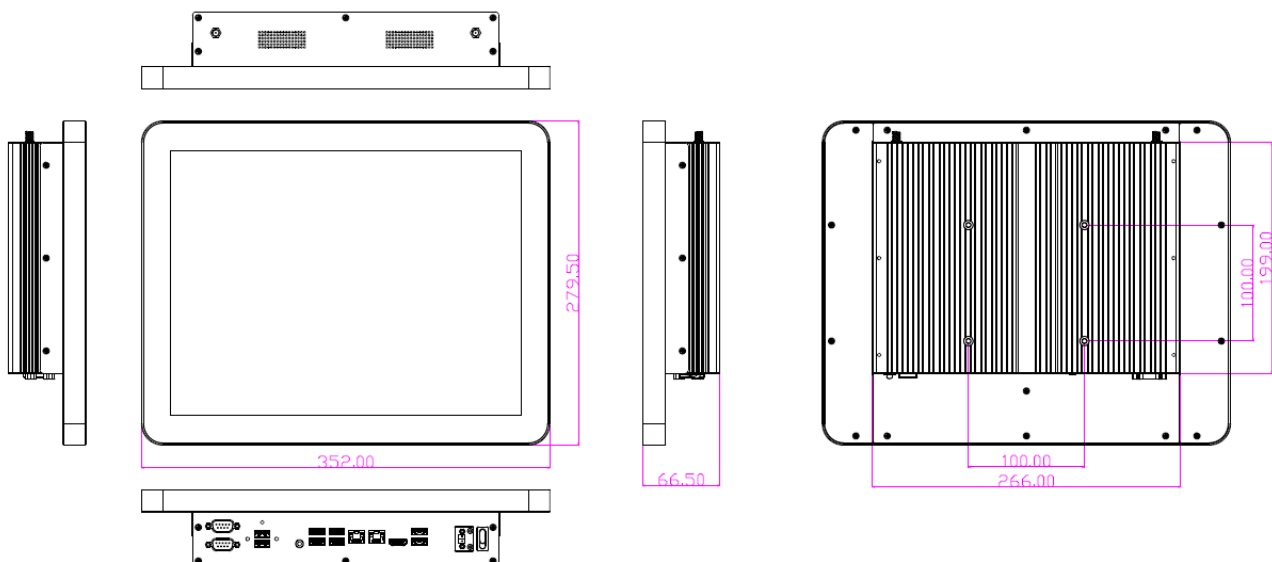

## Optional Accessories

Part Number	Description
-----	HPC150GR-FP6200
	HPC150GR-FP6200 User's Manual
	CD Driver
	Power cord
	60W AC-DC Adapter