



Key Features

- 15" Intel Core i7/i5 Fanless Industrial Panel PC
- Intel 3rd gen. IVY-bridge Core i7/i5 CPU
- 15" LCD 4:3 1024x768 400nits
- Resistive touch with front IP66 design
- Front Panel mount housing
- CE, FCC, VCCI Class A passed
- Optional Mini-PCIe WLAN with external antenna



Outline Drawing

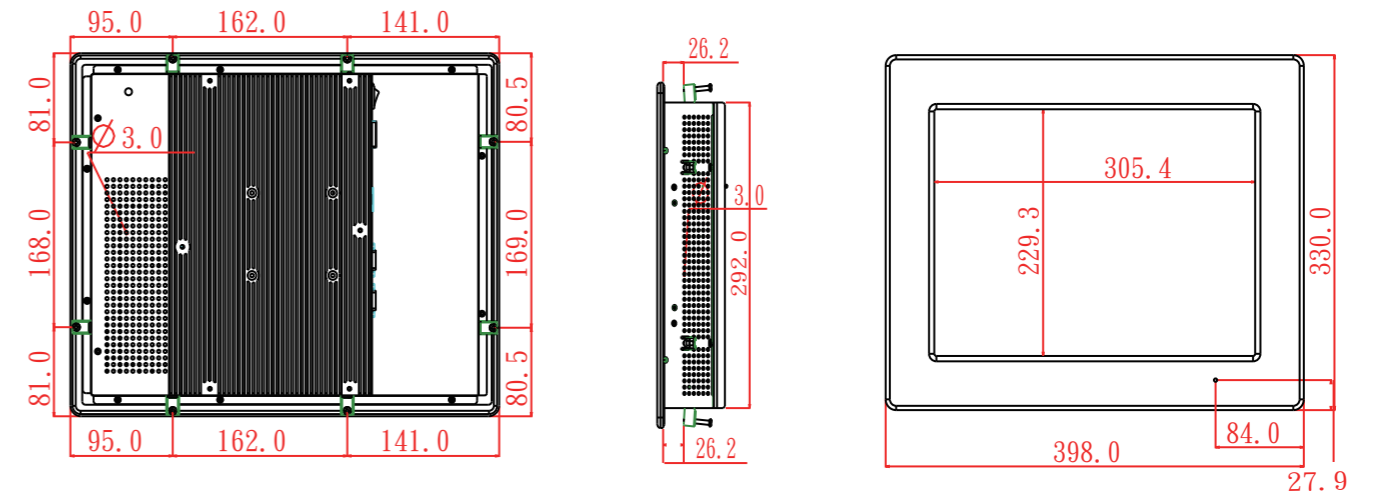

Main System

CPU	FCBGA1023 3rd Generation Intel Core i7/i5/i3/Celeron processor (17W max.)
Chipset	Intel HM65
Graphics	Intel® integrated HD Graphics 4000
Memory	Two 1600 MHz DDR3 SODIMM socket support dual Channel, non-ECC, up to 8 GB

LCD Panel

Size	15" 4:3
Brightness	400 nits
Resolution	XGA (1024 x 768)
Color numbers	16.7M (6-bit x 3 + FRC)
Viewing angle	160 (H) / 160 (V)
Contrast	600:1

I/O & Power & Control Keys

USB	USB 2.0 x 4
COM	DB-9 x 3 {RS232 x 2, RS232/422/485 x 1 (Set by BIOS, RS485 auto flow)}
LAN	RJ-45 x 2 , Gigabit
Audio	Line-out, Microphone-in (3.5 mm phone-jack)
DVI output	DVI-I x 1
Power input	DC-in x 1, 12V~28V
Power adaptor	AC 90 ~ 264V / 47 ~ 63 Hz / DC output 12V, 57W
Power consumption	40.1 watts (MAX. Loading without adaptor)
Control keys	Rear bottom: Power on/off, reset

Touch Panel

Technology	5-wire resistive touch (default)	Projected capacitive touch (option)
Type	Front full flat touch panel	Front full flat 2 point touch panel
Transparency	80±5%	90% ± 3%
Hardness	4H	7H
Durability	Knock 35 million times	Knock 100 million times

* OS support (Multi point) : Win 7 pro, Win 8, Win 8.1 industrial, Win10

Storage & Expansion

HDD	2.5" SATA HDD drive bay x 1 + anti-vibration kit, 320 / 500 GB
Expansion slot	Mini PCIe x 2 (52 pin card-edge type)

Mechanical & Environmental

Housing	Front bezel is Aluminum, others are SECC
IP rating	Front IP66
Cooling	Fanless
Dimension	398 x 330 x 86 mm (W x H x D, panel mount)
Weight (net)	8.5 Kg (approximate, w/o power adaptor)
Temperature	· Operating: 0°C~50°C (w/ air flow) / 0°C~40°C (no air flow) · Storage: -20°C~60°C
Humidity	Operating & storage – 10%~90%, non-condensing
Regulatory	FCC-A, CE (EMC), VCCI, UL

Ordering Information

WLP-7A20-15V BKRT (i5)	R-Touch	Core i5-3317U / 2G RAM / 320G HDD
WLP-7A20-15V BKPT (i5)	P-cap Touch	Core i5-3317U / 2G RAM / 320G HDD

Options

- Wireless or Wireless and BT kit (2 Dipole ant)
- 2.5" SSD
- DC input power plug (black, 1.22m length)
- Stainless front bezel
- Change full flat resistive touch to P-cap touch (BKPT)
- Sliver front bezel
- mSATA module
- Chassis type housing

Customization

- Open frame housing
- Storage door Solution
- Sunlight readable optical bonding
- LCD Auto dimming
- LCD Super dimming (Low brightness)
- TPM
- USB 3.0

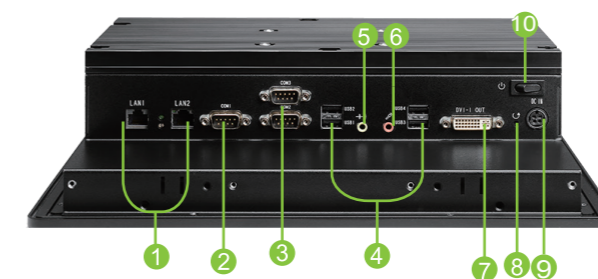

- ① LAN x 2
- ② RS232/422/485
- ③ RS232 x 2
- ④ USB x 4
- ⑤ Line out
- ⑥ Microphone-in
- ⑦ DVI-I
- ⑧ Reset
- ⑨ DC-in
- ⑩ Power on/off

